



BOWLING  
SINCE 1975

ALL PROSPERITY ENTERPRISE CO., LTD.  
LONG TSUEN INDUSTRIAL CO., LTD.  
**BOWLING BRAND STAINLESS STEEL**  
**SERIES AEV AUTOMATIC EXHAUST VALVE**  
made in Taiwan



BOWLING AUTOMATIC EXHAUST VALVE is a reliable automatic venting device and is suitable for venting of air or gas in from pipeline system such as heating systems. It is called Automatic Air Vent.

**Technical Data:**

**Size:** 3/8" – 1" (10mm – 25 mm) **Thread Connection:** NPT/BSPT/BSPP

**Max. Temperatures:** +200°C; **Max. Pressure:** 20 BAR for Float Ball SUS304

**Max. Temperatures:** +100°C; **Max. Pressure:** 10 BAR for Float Ball PP

**Fluid:** Pure water (Floating Ball in PP or SUS304); Light Oil (Floating Ball in SUS304 only)

**Material:**

No.	ABV	MATERIAL
1	VALVE BODY	CF8/ CF8M
2	FLOAT BALL	PP/ SUS304
6	O-RING	SILICON
7	VALVE CAP	CF8/ CF8M
11	INTAKE CAP	BRASS

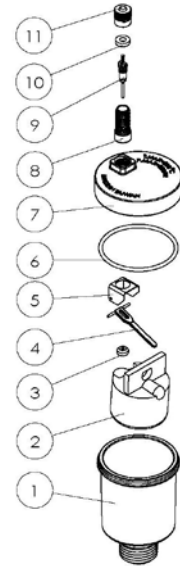

**Optional: Flanged connection**

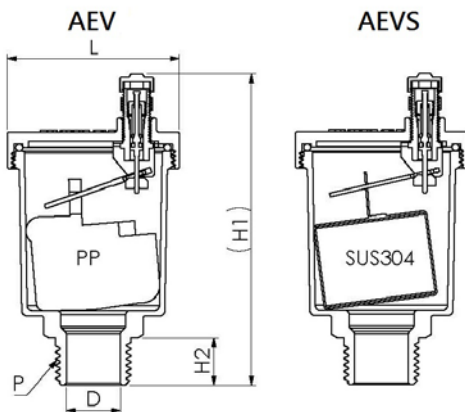
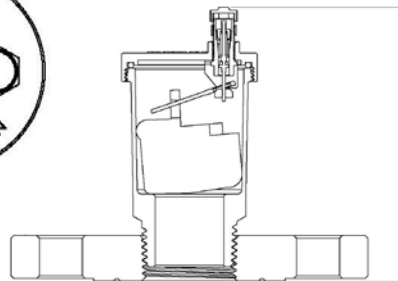

DIMENSIONS (Unit: mm)

Dimension mm				
Size P	L	H1	H2	D
3/8"	47.5	83.5	12.5	11
1/2"		85.8	13	15
3/4"		87.8	15	20.5
1"		90.8	16	24

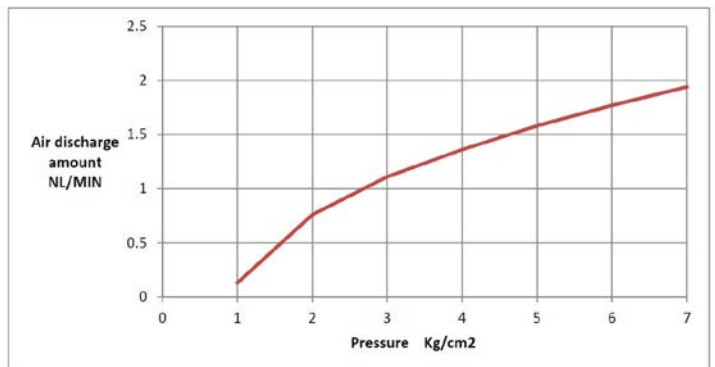

**HOW TO ORDER:**

**TYPE BALL SIZE THREAD PRESSURE**  
**AEVS SUS304 1/2" NPT 5 BAR**

**NOTE:**

Make sure it must be clean in pipeline system before installation. It is not allowed that there is any impurity stuck at the exhaust hole.